

JOYOLIGHT

LS5570

**INSTALLATION
GUIDE**
2019-09

SUSPENSION SYSTEM

**READ CAREFULLY
BEFORE INSTALLATION**

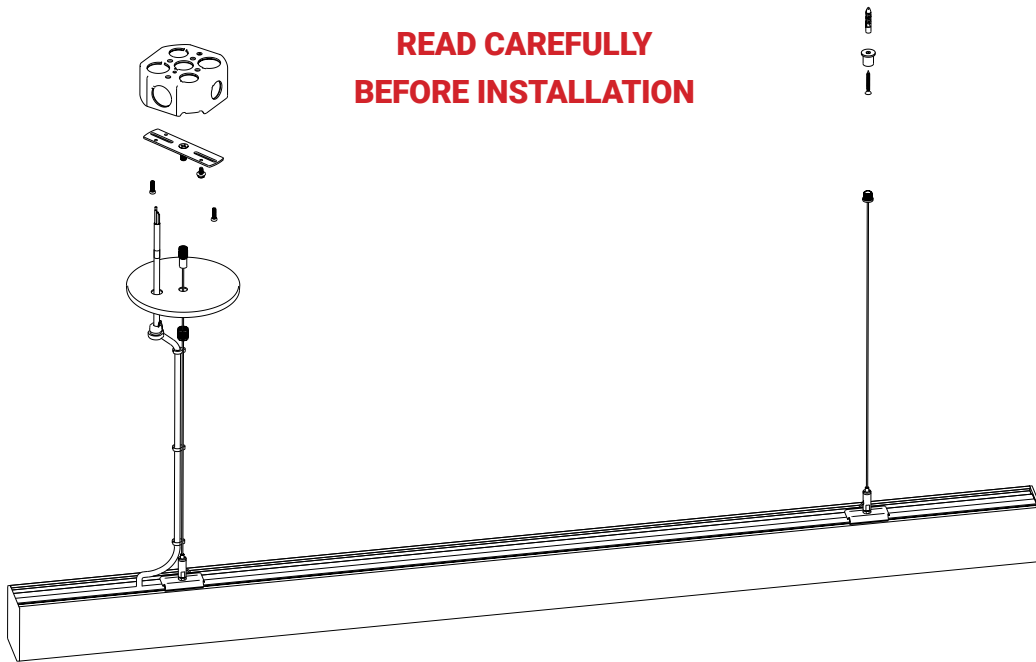

#12, 5200 Dixie Rd,
Mississauga, ON
Canada L4W 1E4
www.joyolight.ca
sales@joyolight.com

 **WARNING**

Failure to comply with the following installation instructions may result in death or serious injury.

- This product must be installed and serviced by a qualified electrician.
- Separate the power supply wiring (110V) and dimming/control wiring
- Disconnect power before installing to avoid electrical shock
- Do not exceed fixture specified voltage
- Power cable should not support the weight of the fixture and stay loose
- Do not use fixture, parts or connectors which are damaged

 **CAUTION**

- Should a production received with missing or damaged parts, please contact Joyolight at 1-877-849-1942.
- Should a fixture not work properly, please turn fixture off and contact Joyolight technical support for immediate assistance.
- Handle the fixture with care throughout the installation in case of damaging the fixture.
- Always wear clean latex or cotton gloves to avoid spots or fingerprint marks on the fixture.
- Unauthorized field repairs will void warranty

SUSPENSION SYSTEM OVERVIEW

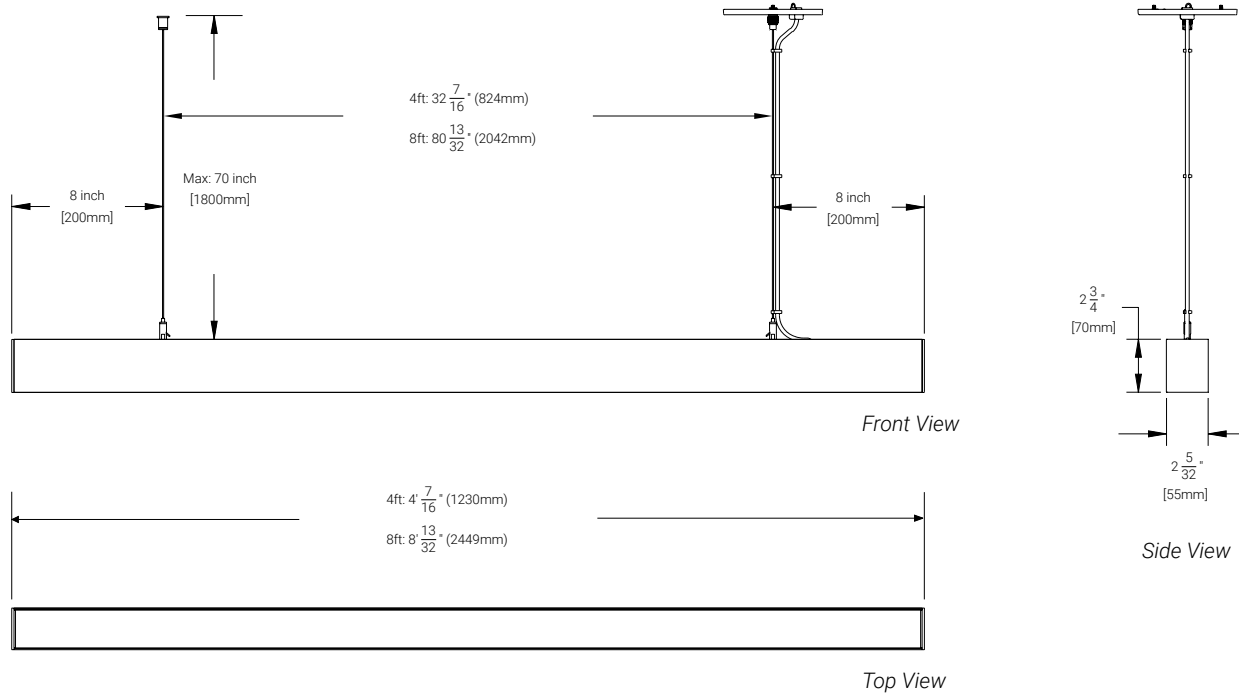

Accessories

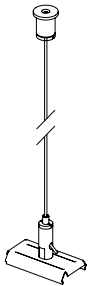

PW-NC-01
Pendant wire,
Non-power side
with clips,
70 inches

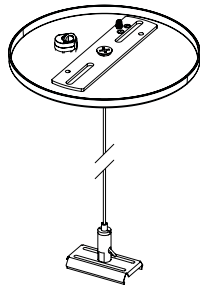

PW-PC-01
Pendant wire,
Power side
with clips, canopy
70 inches

Intallation Instructions

Step 1: Install the Canopy and Power Cable

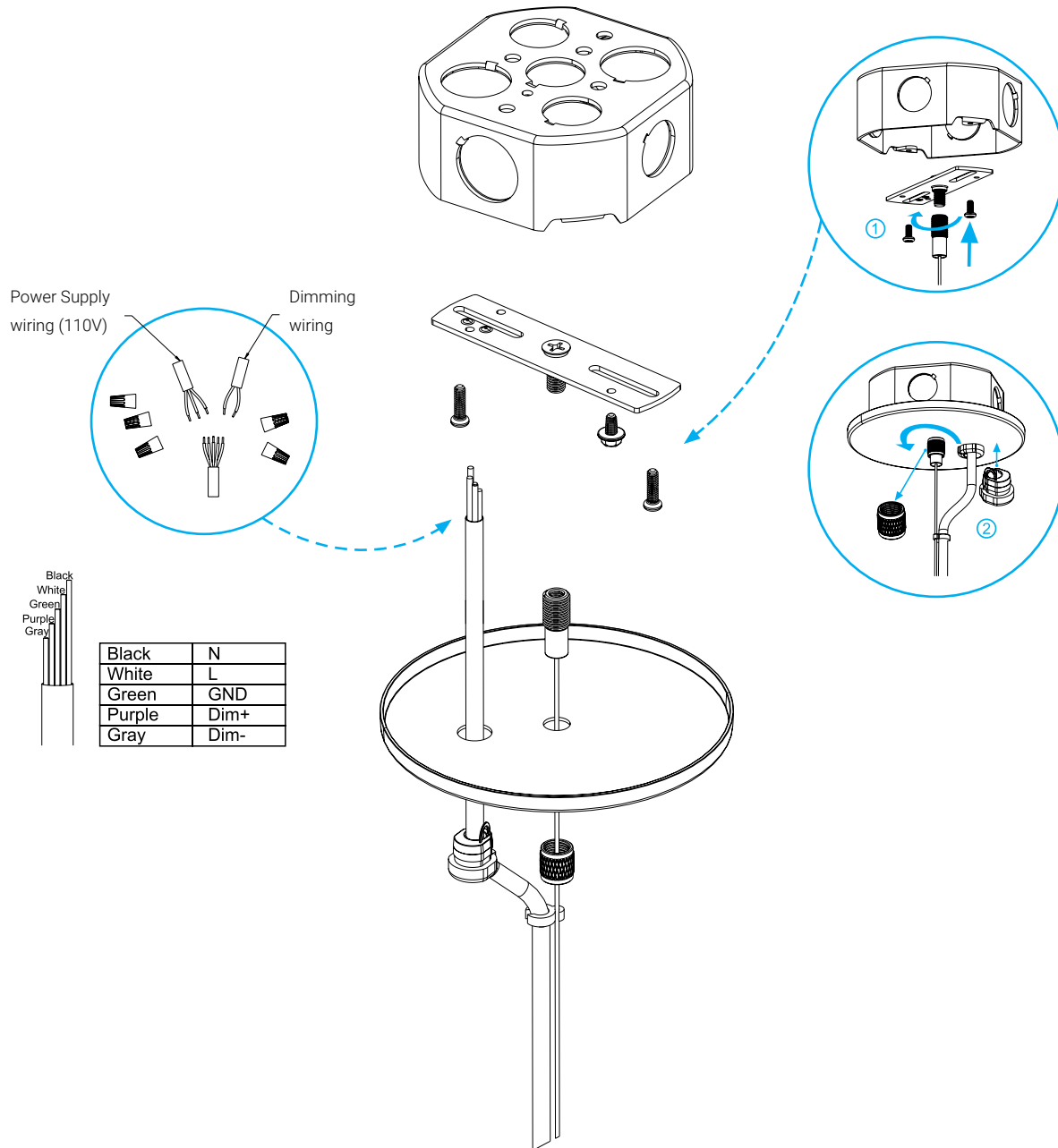

Step 2: Install the Suspension Components

Drill holes on the wall first
 [Drill bit diameter: $\frac{15}{64}$ " (6mm)]

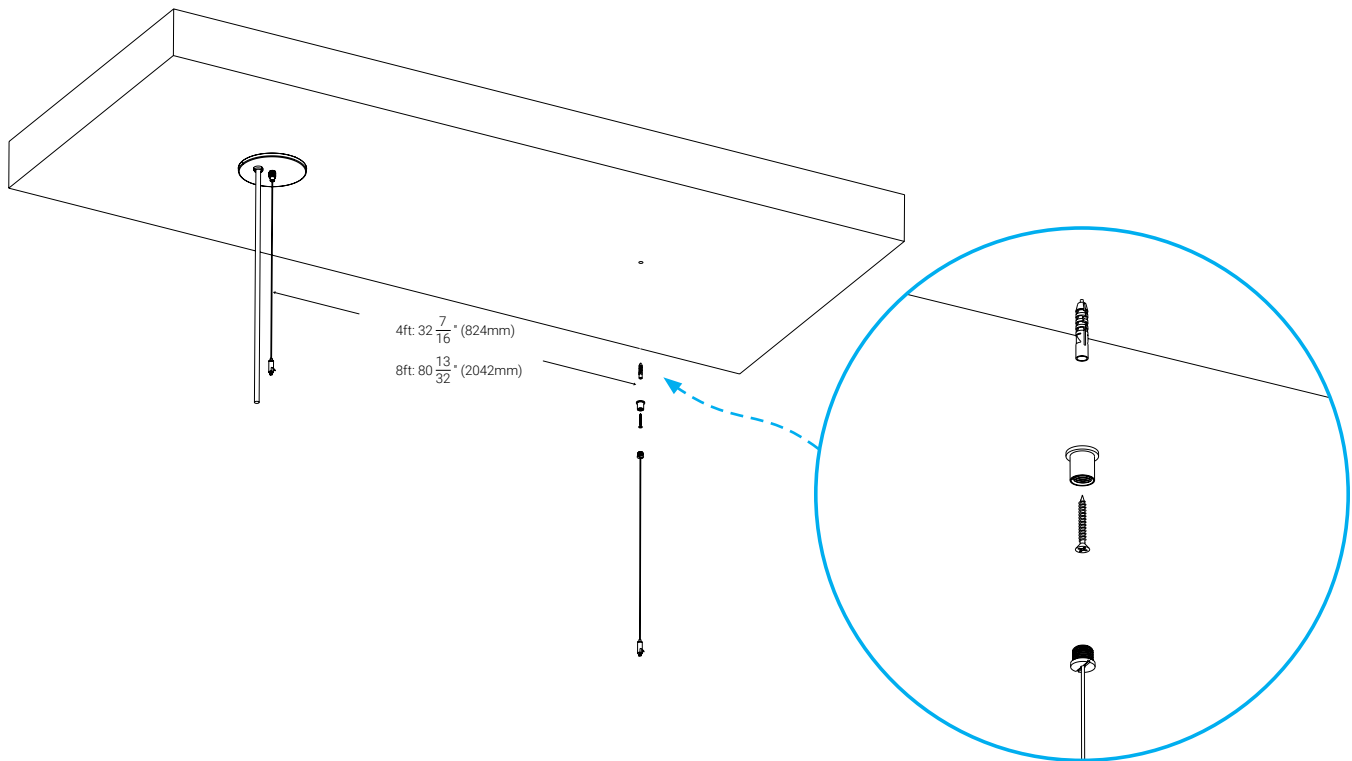

Step 3: Install the clips

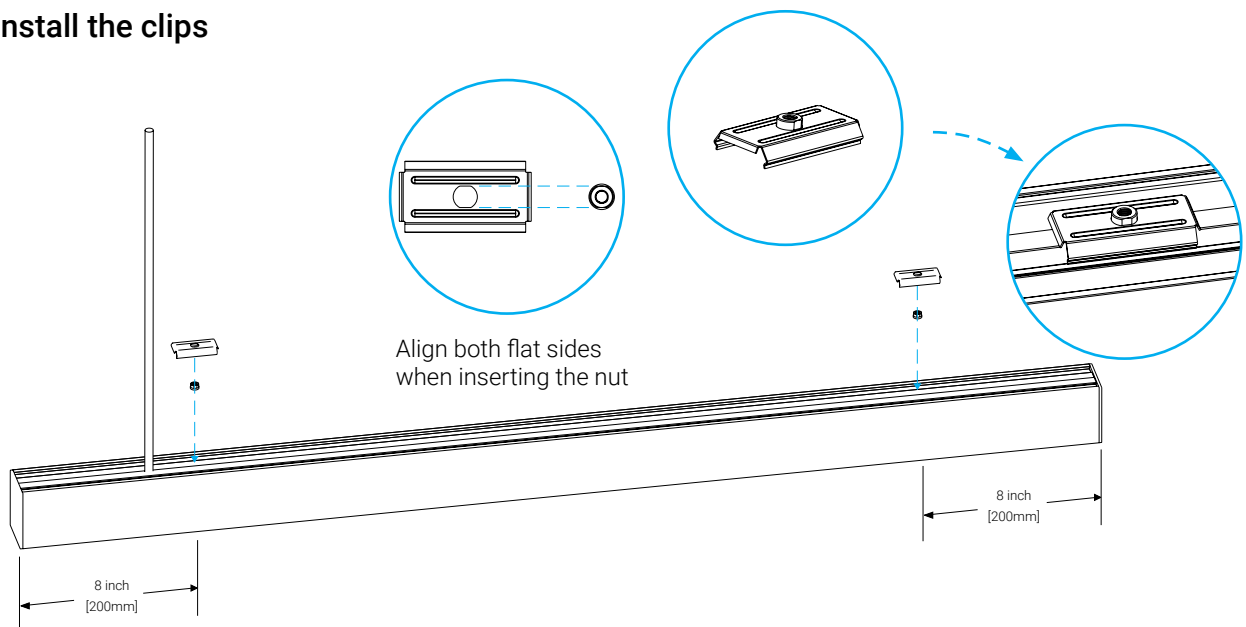

Step 4: Install the fixture

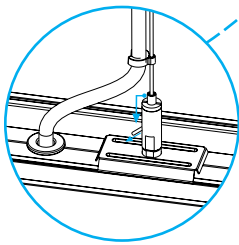
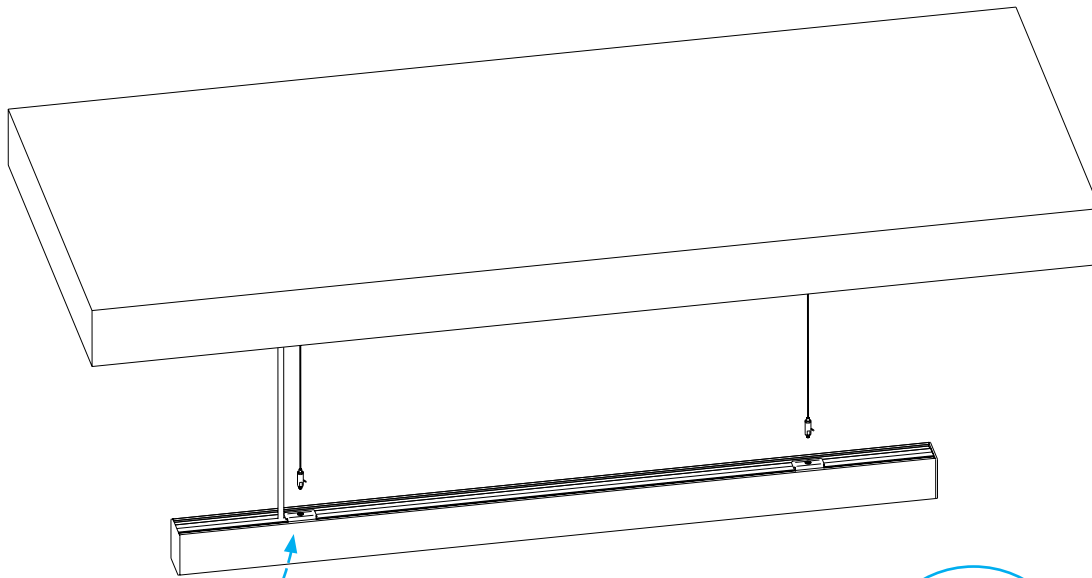

Hold down the upper little cylinder and adjust the steel cable.

Clips can be adjusted horizontally

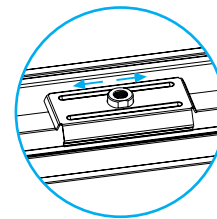

Tighten the screw and fix the position of the clip.

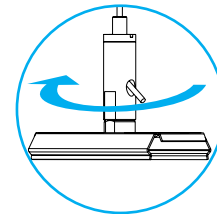

Hold down the upper little cylinder and adjust the steel cable.

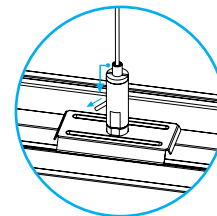

Step 5: Complete the installation

