

LS0709 INSTALLATION GUIDE (RECESSED)

⚠ WARNING Failure to comply with the following installation instructions may result in death or serious injury.

- This product must be installed and serviced by a qualified electrician.
- Separate the power supply wiring (110V) and dimming/control wiring
- Disconnect power before installing to avoid electrical shock
- Do not exceed fixture specified voltage
- Do not expose IP33-rated lighting fixtures or LED strip to moisture generated from steam, water drips, as well as condensation residues, as it will cause damage to the light components causing a possible short circuit.
- Power cable should not support the weight of the fixture and stay loose
- Do not use fixture, parts or connectors which are damaged

⚠ CAUTION

- Should a production received with missing or damaged parts, please contact Joyolight at 1-877-849-1942.
- Should a fixture not work properly, please turn fixture off and contact Joyolight technical support for immediate assistance.
- Handle the fixture with care throughout the installation in case of damaging the fixture.
- Always wear clean latex or cotton gloves to avoid spots or fingerprint marks on the fixture.
- Unauthorized field repairs will void warranty

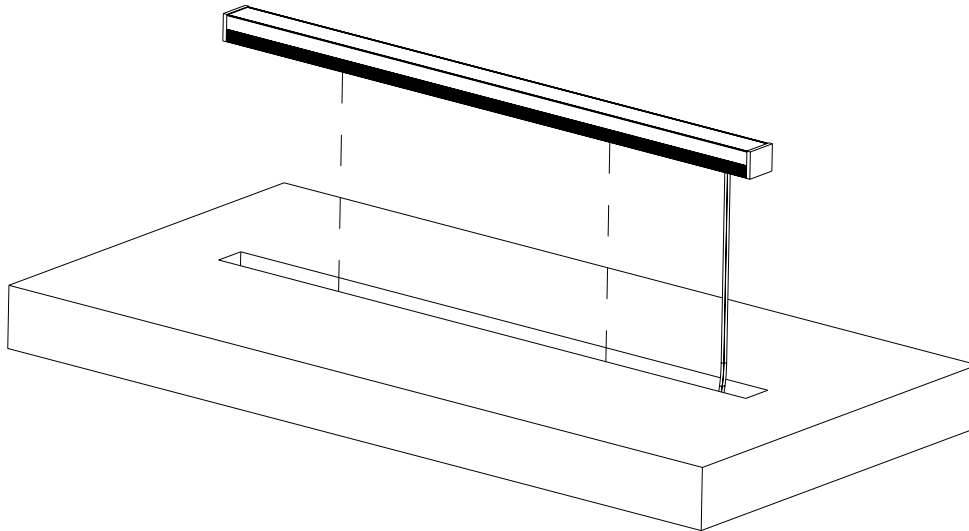

STEP 1:

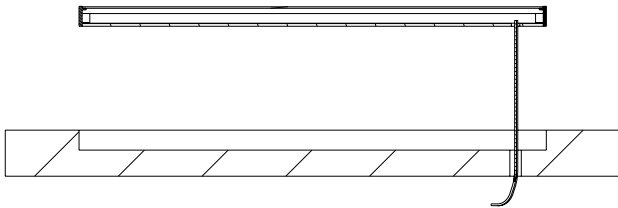

- Pull wires through the hole.

STEP 2:

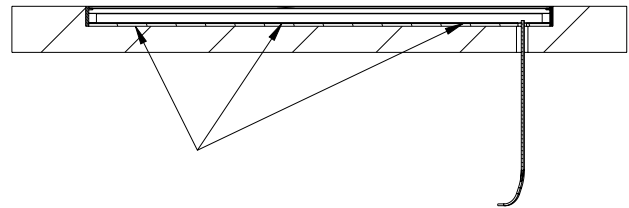

- Glue the fixture on.

JOYOLIGHT

Joyolight reserves the rights change our products and specifications at anytime without prior notice and such modification shall be effective immediately. Contact Joyolight for the latest product information.

Five-year warranty

Contact us for complete terms and conditions.

JOYOLIGHT GROUP INC.

#12, 5200 Dixie road
Mississauga, ON, L4W 1E4

www.joyolight.ca
sales@joyolight.com
1-877-849-1942
647-496-8107